



TE - Container heater

Product description

Our container heaters are installed inside fermentation tanks. With our proven mounting system, we guarantee stability and safety in all operating modes and ensure a constant heat input into the fermentation process.

Facts

- Made entirely of stainless steel
- Standard sizes up to DN 150
- Operating pressures up to 16 bar
- Wall ducts compliant with Ordinance on Installations for Handling Substances Hazardous to Water (AwSV)
- Proven mounting system
- Robust and durable design
- Individual and tailor-made solutions
- Customer-specific design

Areas of application

- For concrete containers
- For steel containers

Options & variants

- Easy temperature control
- Integration into the heating system
- Installation and commissioning by our specialised personnel

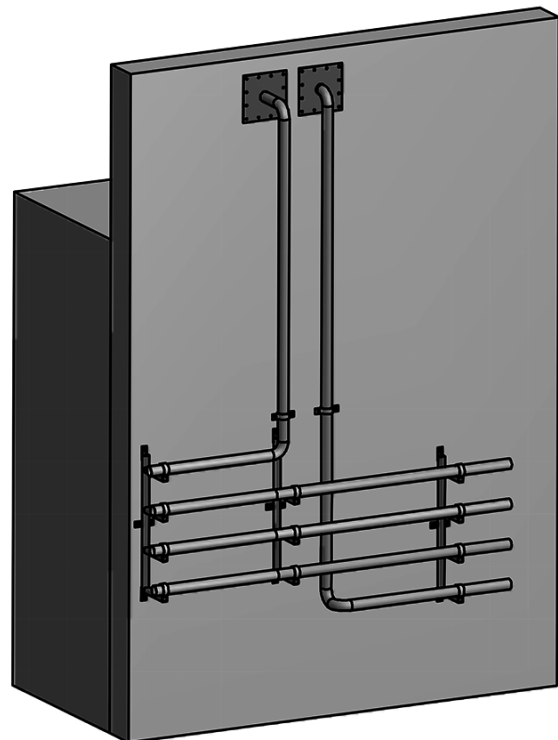

Our certifications

- Specialist company according to German Water Resources Act (WHG)
- Pressure Equipment Directive AD 2000 HPO
- DIN EN ISO 3834-2
- DIN EN 13445-4



Triptiser Edelstahl GmbH
ROHRLEITUNGS- UND ANLAGENBAU

www.triptiser-edelstahl.de

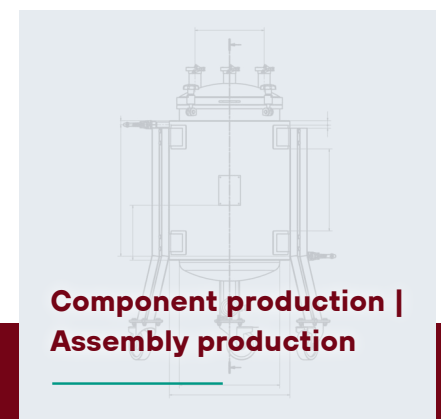
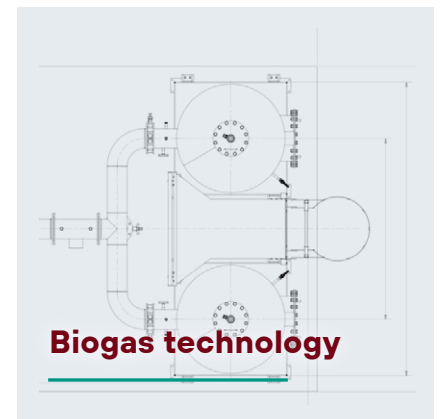

Your partner for all tasks in pipeline and plant construction

We convince

With over 30 years of experience in handling and processing stainless steel, we are highly specialised in pipeline and plant construction for environmental and supply technology. We attach particular importance to close and trusting cooperation with our customers. Thanks to our many years of experience and our extensive know-how, we can offer individual solutions and therefore meet the expectations of our customers.

We would be happy to make you an individual offer.

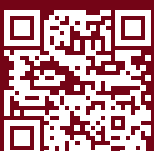

Triptiser Edelstahl GmbH
Straße der Deutschen Einheit 12
D-07819 Triptis

Tel: 036482 25 39 00
E-Mail: info@triptiser-edelstahl.de
www.triptiser-edelstahl.de